

SERVICE MANUAL

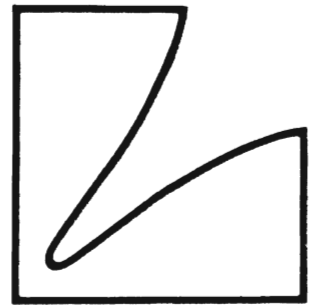

LUXMAN STEREO CASSETTE DECK

K-210

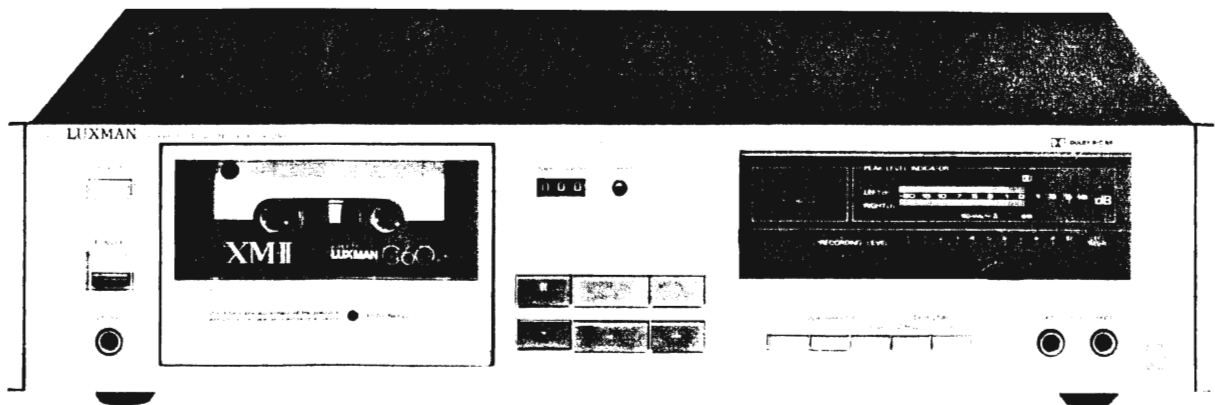

Contents

Level Diagram -----	1
Adjustment Location -----	2
Adjustment Procedures -----	3 - 4
Exploded View -----	5
Exploded View Parts List -----	6
Exploded View (Mec -----	7
Exploded View Parts List (Mechanism) -----	8
Packing Material Parts List -----	9
Master P.C.B. Parts List -----	10 - 12
FL Meter P.C.B. Parts List -----	12
REC LED P.C.B. Parts List -----	12
Head Phone P.C.B. Parts List -----	12
IC Handling Guide -----	13
Destination's Parts List -----	13
Schematic Diagram -----	14 - 15
Specifications -----	16

Level Diagram

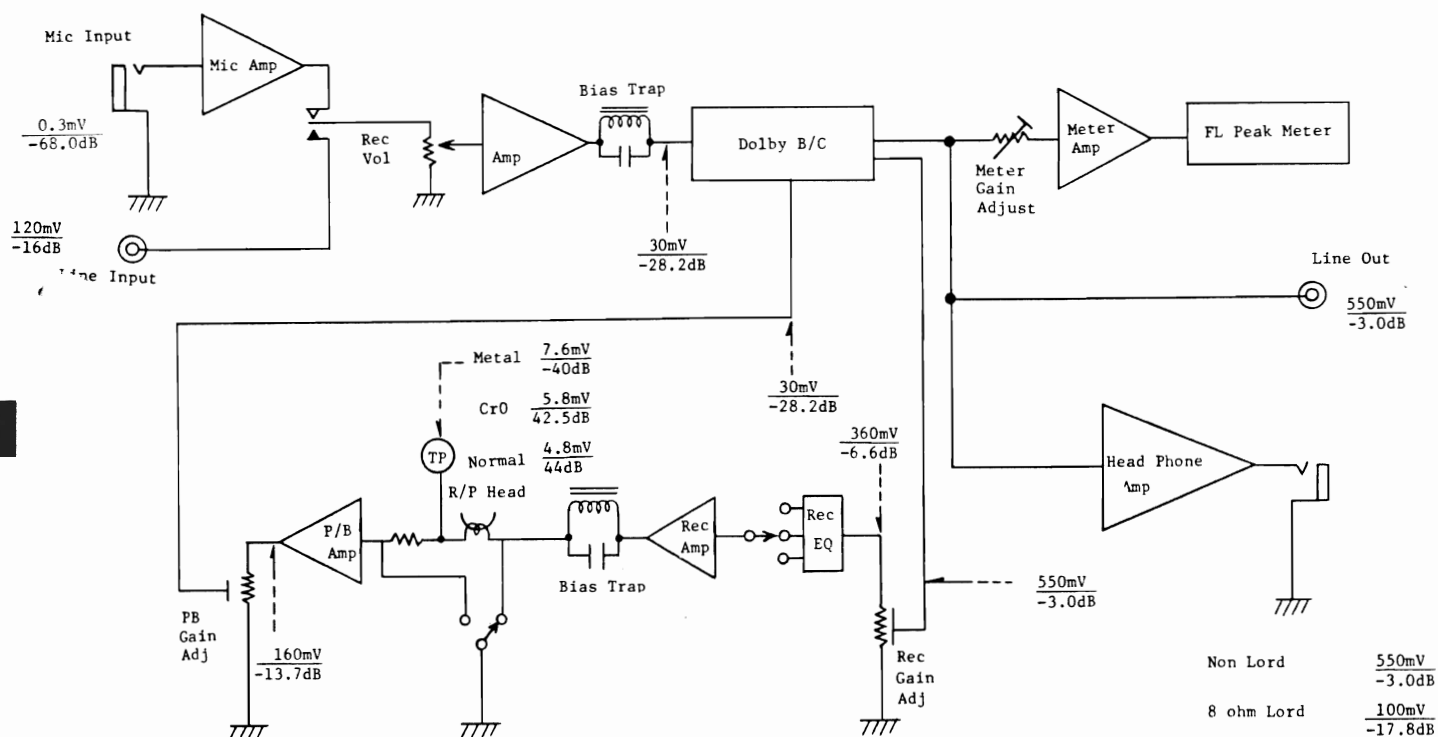

0dB = 775 mV 400Hz

Adjustment of Location

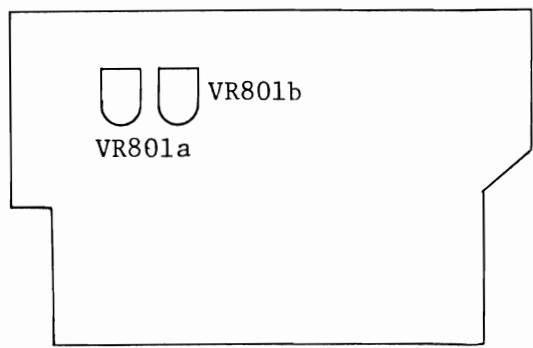
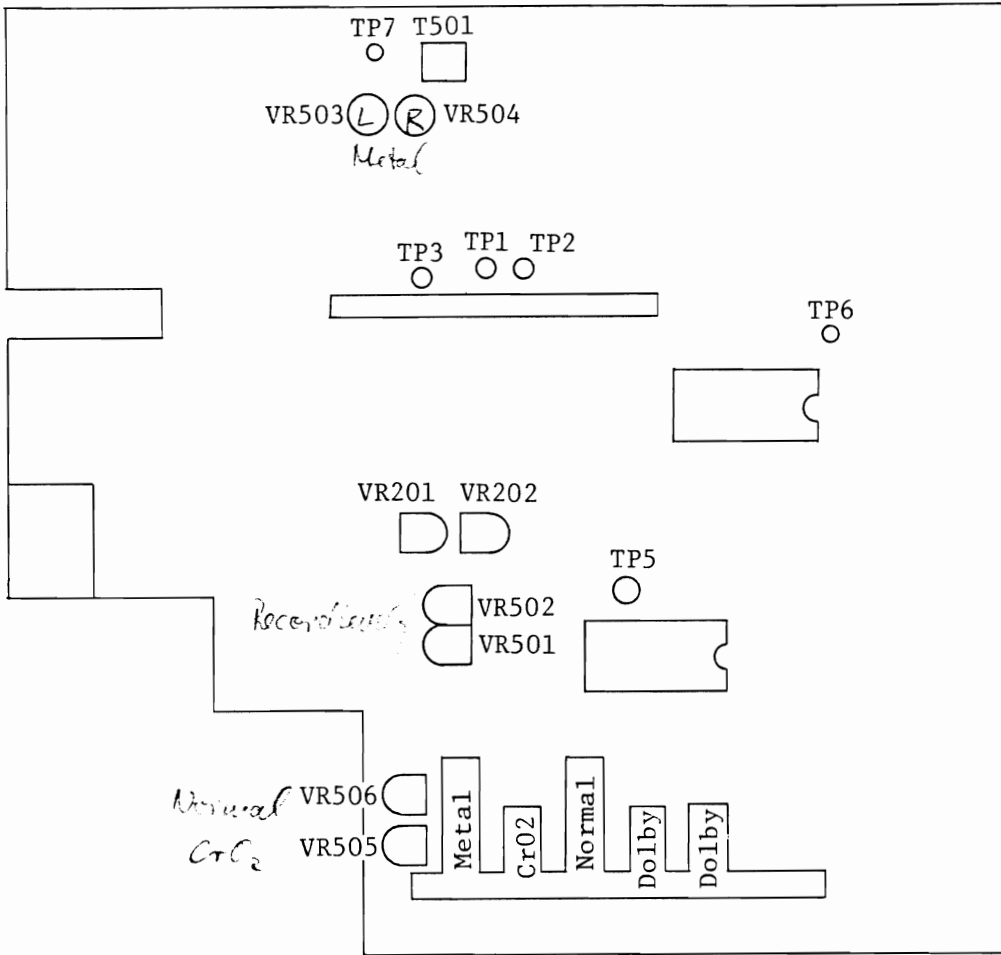

- VR201 Playback Dolby Level Adjusting (L-ch)
- VR202 Playback Dolby Level Adjusting (R-ch)
- VR501 Record Level Adjusting (L-ch)
- VR502 Record Level Adjusting (R-ch)
- VR503 Bias Current Adjusting, Metal (L-ch)
- VR504 Bias Current Adjusting, Metal (R-ch)
- VR505 Bias Current Adjusting, CrO2 (L/R-ch)
- VR506 Bias Current Adjusting, Normal (L/R-ch)

- T501 Bias OSC Frequency Adjusting

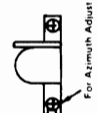
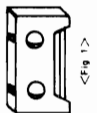
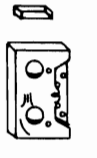
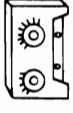

K-210

Adjustment of Location

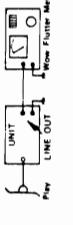
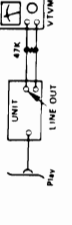
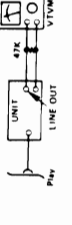
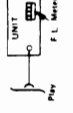
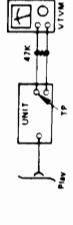
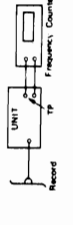
Step	Description	Mode	Adjusting Point	Test Point	Connection	Remarks
1	Tape Transportation Check	Play	R/P Head For Azimuth Adjust 	Skew Head Head & Guide Gage N. 300 		Made sure that does not touch the tape guide of erase and R/P heads, by using "Skew Half". Confirm that R/P head is placed without any tilt against the "M-300" gage.
2	Torque Check	Play, FF & Rew			Torque Meter 	Take Up Torque : 35-60 g.cm Back Tension Torque : 2-6 g.cm FF & Rew Torque : 70-130 g.cm
3	Tape Speed and Wow Flutter Check	Playback	For Speed Adjust Motor 	Line Out		Test Tape : MTT-111 (3KHz) Speed : 3000Hz \pm 1.5% Wow Flutter : No more than 0.06% (JIS W.R.M.S.)
4	Head Azimuth Adjustment	Playback	See [Fig.1]	Line Out		Test Tape : MTT-114 (10KHz) or MTT-215C (315Hz, 10KHz) Line Out : Maximum of both channel
5	Playback Dolby Level Adjustment	Playback Tape Select: Normal Dolby NR: Off	VR201 Lch VR202 Rch	Line Out		Test Tape : MTT-150 (400Hz, 200nWb/m) Line Out : 550mV
6	FL Meter Adjustment	Playback	VR801a Lch VR801b Rch	Meter Display		Test Tape : MTT-150 Meter Display : 0 dB
		Playback Tape Select: Normal Dolby NR: Off	Step 1-5	Line Out		Test Tape : MTT-217L or MTT-215C
		Playback Tape Select: Cr02 Dolby NR: Off				Test Tape : MTT-114 or MTT-215C
7	Bias OSC Frequency Response Check	Playback Tape Select: Metal Dolby NR: Off	T501	TP7-GND		Input : Non TP Output : 105KHz \pm 5KHz 220mV \pm 20mV
		Playback Tape Select: Metal Dolby NR: Off				

Step	Description	Mode	Adjusting Point	Test Point	Connection	Remarks
9	Bias Current Adjustment	Record Tape Select: Metal Dolby NR: Off	VR503 Lch VR504 Rch	TP1-TP3 TP2-TP3 (GND)		
		Record Tape Select: Cr02 Dolby NR: Off	VR505 L/Rch			Input : Non TP Output : 50mV (0.5mA)
		Record Tape Select: Normal Dolby NR: Off	VR506 L/Rch			Input : Non TP Output : 36mV (0.36mA)
10	Input Level Adjustment	Record Tape Select: Normal Dolby NR: Off	Rec Level VR	Line Out		Input : 120mV Line Out : 550mV
11	Record Level Adjustment and Check	Record/Play Tape Select: Metal Dolby NR: Off	VR501 Lch VR502 Rch	Line Out		Input : 120mV Line Out : 550mV
		Record/Play Tape Select: Cr02 Dolby NR: Off				
		Record/Play Tape Select: Normal Dolby NR: Off				
12	Record/Playback Frequency Response Check	Record/Play Tape Select: Metal Dolby NR: Off	Step 8-11	Line Out		Record Tape : AC-711 Input : 20Hz-18KHz 4.5mV
		Record/Play Tape Select: Cr02 Dolby NR: Off				Record Tape : AC-512 Input : 20Hz-17KHz 4.5mV
		Record/Play Tape Select: Normal Dolby NR: Off				Record Tape : AC-223 Input : 20Hz-16KHz 4.5mV
13	Record/Playback Frequency Response Check (Dolby)	Record/Play Tape Select: M.C.N. Dolby NR: B, C				Record Tape : AC-711, AC-512 AC-223 Input : 20Hz-12.5KHz 4.5mV

EXPLODED VIEW
K-210

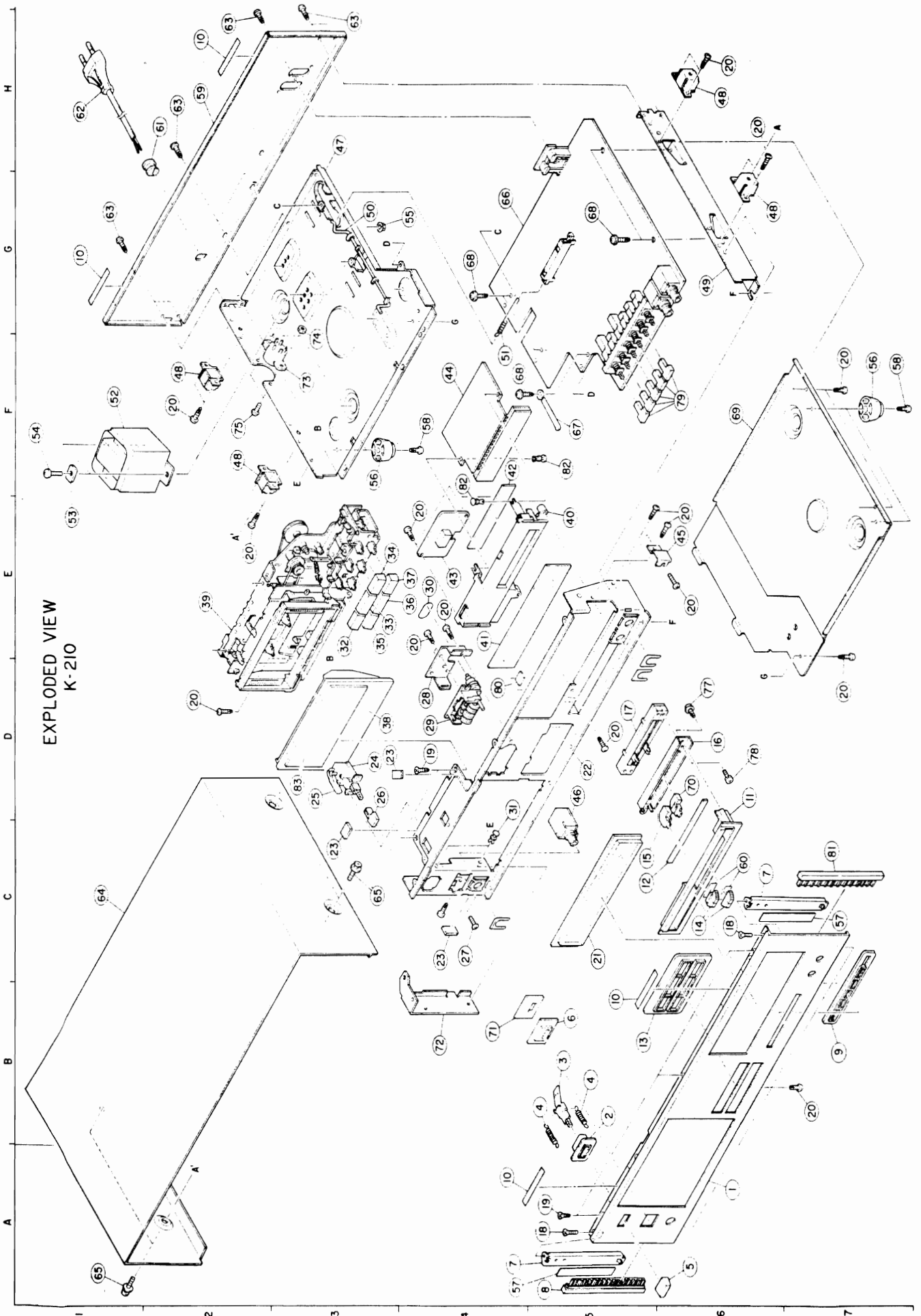

Exploded View Parts List

Index	Symbol No.	Stock No.	Description
A6	1	64D57151F01	Panel, Front
B5	2	07A45558F04	Frame, Eject
B5	3	45A44338F01	Lever, Eject
B5	4	41A45559F01	Spring, Eject
A6	5	36A44340F05	Knob, Eject
B5	6	61A56641F01	Crystal, Indicator
A4, C6	7	07A57175F01	Bkt, Side Panel
A5	8	07B56624F01	Frame, Panel Side
B7	9	07B57161F01	Frame, Push Knob
A4, B5	10	75B44632C04	Pad, Cushion
D6	11	13C57168F01	Escutcheon, Vol
C5	12	43A57191F01	Spacer, Escut
B5	13	07B57159F01	Frame, Function
C6	14	36B57177F01	Knob, Control
C5	15	43B57179F01	Spacer, Knob Cont "B"
D6	16	07B57169F01	Bkt, Slide VR
D5	17	18T52629F01	VR, Slide S60B2PA 20K
C6, A5	18	03S444205G16	Scr, T-Tite M3x6
D4, A5	19	03S40012G26	Scr, Tpg M3x6
D2, B7	20	03S40012G03	Scr, Tpg M3x6
C5	21	61B57170F01	Crystal, Meter
D5	22	27D57158F01	Chas, Front
C3, C4	23	75A42565P15	Cushion, Rubber
D3	24	40T45561F02	SW, Power SDLIP (SK, AK, EK, SG)
		40T47454F01	SW, Power SDLIP-UL (UP)
D3	25	08T57437F09	Cap, DE7150 FZ 103P
D3	26	36A56639F02	Knob, Push 1171
C4	27	03C40014G09	Scr, Mch M3x5
D4	28	07A50169F01	Bkt, Counter
D4	29	72T50177F03	Tape, Counter
E4	30	42A50299F01	Belt, Counter
D4	31	05B41635J04	Rivet, Push
E3	32	36A57154F01	Knob, Pew
E3	33	36A57152F01	Knob, Play
E3	34	36A57155F01	Knob, FF
E3	35	36A57156F01	Knob, Rec
E4	36	36A57153F01	Knob, Stop
E4	37	36A57157F01	Knob, Pause
D3	38	64B57188F01	Plate, Door
E2	39	01U56000F89	FT85E11C, CAS DK
E5	40	07C57182F01	Frame, Meter
D4	41	91A57160F01	Filter, Meter A
F4	42	91A57184F01	Filter, Meter B
E4	43	01V58700F81	Ass'y, Rec LED PCB
F4	44	01V58500F84	Ass'y, FL Meter PCB
E6	45	07A57273F01	Bkt, Side

Index	Symbol No.	Stock No.	Description
D5	46	01V58800F27	Ass'y, Head Phone PCB
H3	47	27D57405F01	Chas, Bottom
G6, F2	48	07A57185F01	Bkt, Side
G6	49	27C50163F01	Chas, Side
G3	50	45A57682F01	Link, Rec
F4	51	41A57681F02	Spring, Record
F1	52	25T57308F01	Trans, Power (SK)
		25T57166F01	Trans, Power (EK, AK, SG)
		25T56955F01	Trans, Power (UP)
E1	53	07A40871F01	Support, Trans Wsr.
F1	54	03S40011G93	Scr, Mch M3x8
G4	55	02B47353F02	Nut, Hex M3
F7, F3	56	75A52969F01	Pad, Trann-Leg
A4, C7	57	14S53018F52	Insulator (50x12)
F4	58	03S40036U05	Scr, T-Tite M3x8
H2	59	15C50166F17	Cover, Rear (SK, EK)
		15C50166F18	Cover, Rear (SG)
		15C50166F16	Cover, Rear (AK, UP)
C6	60	75A57370F01	Pad, Cushion
H2	61	43B41625J02	Support, Cord (SK, AK, EK)
		43B41625J01	Stopper, Cord (UP)
		07A40070U01	Bkt, AC Cord (SG)
H1	62	28T50179F03	Cord, AC (SK, AK, EK)
		30T43811F01	Cord, AC 3 Lead (SG)
		28T40916U01	Plug, AC Cord (UP)
H2, G1	63	03S40012G41	Scr, Tpg M3x8
C1	64	15D57189F01	Cover, Top
A1, C3	65	03S40036U01	Scr, T-Tite M4x8
G4	66	01V58900F12	Ass'y, Master Board (SK, AK, SG)
		01V58600F92	Ass'y, Master Board (EK, UP)
F5	67	29C41045F01	Lug Wrap Around
G4, F4	68	03S40018G01	Scr, Tpg M3x6
F6	69	15C57404F01	Cover, Bottom
D6	70	43B57178F01	Spacer, Knob Cont "A"
B4	71	43A56628F01	Spacer, Power
B4	72	26B56495F01	Shield, SW
F3	73	40T40705T04	SW, Select (EK, AK, SG)
F3	74	02S40000G12	Nut, Hex M3 (EK, AK, SG)
F2	75	03S40011G93	Scr, Mch M3x8 (EK, AK, SG)
D6	77	03S40018G02	Scr, Tpg M3x8
D6	78	03C40014G12	Scr, Mch M2.6x4
F6	79	36A57176F01	Knob, Push (A)
E5	80	14S53017F05	Insulator
C7	81	07B56624F02	Frame, Panel Side
F4, F5	82	05B41635J03	Rivet Push
D3	83	61C57187F01	Crystal, Door

Mechanism Exploded View Parts Ljst

Index	Symbol No.	Stock No.	Description	Index	Symbol No.	Stock No.	Description
D3	1	F011-126	Ass'y, Chassis	F6	57	FK13L-13	Guide, Spring
D4	2	F014-053	Ass'y, Pinchroller	G2	58	FK11A-17	Spring, Accidental Erase
B5	3	F029-143	Head, R/P	E2	59	FK11A-18	Spring, Motive Play
B4	4	F030-054	Head, Erase	C3	60	FK568-11	Spring, Door
E7	5	F035-023	Ass'y, FF Lever	D4	61	FK569-13	Spring, Pinchroller
C5	6	FR345-12	Base, Head	B2	62	FK573-11	Spring, Arm Lock
E2	7	FR346-11	Base, Assist	G3	63	FF11M-13	Belt, Drive
F6	8	FC15K-13	Lever, Play	F4	64	FF11N-11	Belt, Sensor
E4	9	FC15M-14	Lever, Stop	F3	65	FP462-11	Belt, Main
C7	10	FC15Y-12	Base	D1	66	FP463-11	Belt, Sub
G2	11	FC15R-12	Lever, Accidental Erase	E4	67	UE11L-11	SW, Leaf
G4	12	FC15U-12	Spring, Key	C7	68	UE12B-11	SW, Leaf
E1	13	FC15W-12	Bkt, Motor	B2	69	FP472-11	Ass'y, Dumper
C2	14	FR349-13	Bkt, Dumper	F3	70	FR12U-11	Ass'y, Flywheel
G1	15	FC15S-12	Arm, Accidental Erase	D1	71	FP470-11	Ass'y, Clutch
C1	16	FC11H-12	Arm, Eject Lock	C3	72	FP471-11	Ass'y, Take Up Reel
D4	17	F226-013	Ass'y, Bkt.	C3	73	FP487-12	Ass'y, Supply Reel
D2	18	FK551-12	Spring, Cassette	G1	74	WH17K-00	Connector, Cable
C3	19	FK579-11	Spring, Back Tension	A5, B5	75	FG137-15	Scr, F Lock
C1	20	FR352-11	Lever, Safety	E2	76	FG114-15	Scr,
C5	21	FM283-13	Spacer, Head	C2	77	UG11D-11	Scr, T-Tite
F2	22	FM123-12	Spacer	D6	78	FG177-16	Scr, T-Tite M2.6x8
A4	23	FK553-12	Holder, Spring	D2, F6	79	KG194-28	Scr, T-Tite M2.6x4
B6	24	FD19L-12	Door, Frame	B1	80	KG194-14	Scr, T-Tite M3x8
D7	25	FD13W-16	Lever, Lock	C7	81	FG177-22	Scr, T-Tite M2.6x10
E7	26	FD13E-12	Lever, Pause Lock	E4	82	FG178-18	Scr, T-Tite M3x6 Flat
D6	27	FD13K-11	Arm, Pause	B1, C2	83	FG194-12	Scr, Mch.
E4	28	FD13D-11	Arm, Play	C2, E4	84	KG189-11	Scr, T-Tite M3x4.5
D4	29	FD13L-12	Arm, Stop	D4	85	FJ183-12	Washer, Tooth Lock
D5, E5	30	FD13P-13	Key, FF	C2	86	FM296-11	Spacer
D5	31	FD13R-13	Key, Play	G1	87	FJ123-19	Washer, Lock 3.5
C5	32	FD13S-13	Key, Rec	D4, E3	88	FJ123-21	Washer, Lock
C5	33	FD13T-11	Key, Stop	C4	89	FJ123-14	Washer, Lock
C6	34	FD13U-12	Key, Pause	E3	90	FJ111-14	Washer, Polyslider
D6	35	FD13V-12	Shaft, Lock Lever	C3	91	FJ111-19	Washer, Polyslider
E5	36	FD13Y-14	Plate, Arm	F3	92	F224-011	Ass'y, Shutt off Mecha
E6	37	FD13M-11	Arm, FF	F1	93	F064-116	Ass'y, Motor
E5	38	FD13N-11	Arm, REW	D2	94	FP469-12	Ass'y, Idler
C1	39	FD11G-11	Stopper, Rec	F3	95	FD16B-12	Arm, Head Base
D1	40	FD13F-11	Arm, FF Lever	F3	96	FD16G-11	Bush
E1	41	FD13H-12	Arm, Motive Play	C1	97	FK11C-11	Spring, Brake Arm
E3	42	FM153-12	Gear, Play	E4	98	FF12R-11	Cushion
C4	43	FN154-13	Gear, Idler	D1	99	FK12E-12	Spring, FF
C1	44	FD17T-12	Arm, Record	C6	100	KG194-46	Scr, T-Tite M3x6.5
C4	45	FR358-12	Reference, Guide	E7	101	FK11A-56	Spring, Lock
D4	46	FR360-12	Guide, Cassette	C3	102	FK578-13	Spring, Head Base
B5	47	FK572-11	Spring, Azimuth	C4	103	FP464-11	Cushion, Pad
B4	48	FK572-12	Spring, Azimuth	D6	104	FH126-11	Wire, Bind
E2	49	FK574-12	Spring, Assist Base	C3	105	FJ111-12	Washer, Polyslider
D1	50	FK575-11	Spring, Play Idler	F2	106	FP12E-14	PCB
D2	51	FK577-12	Spring, Head Base	F2	107	KG194-35	Scr, T-Tite M2x5
G2	52	FK11A-43	Spring, Arm	B1	110	43A51937F01	Spacer, Eject
D6	53	FK12F-12	Spring, Pause	B3	111	15B44924F05	Cover, Dust.
D7	54	FK11A-45	Spring, Lock	B3	112	61A44936F01	Lens, Indicator
E4	55	FK11A-16	Spring, Stop	B3	113	65C42544U06	Lamp, Pilot
F6	56	FK11F-22	Spring, FF	A4	114	03S40036U03	Scr, T-Tite M3x6

Packing Material Parts List

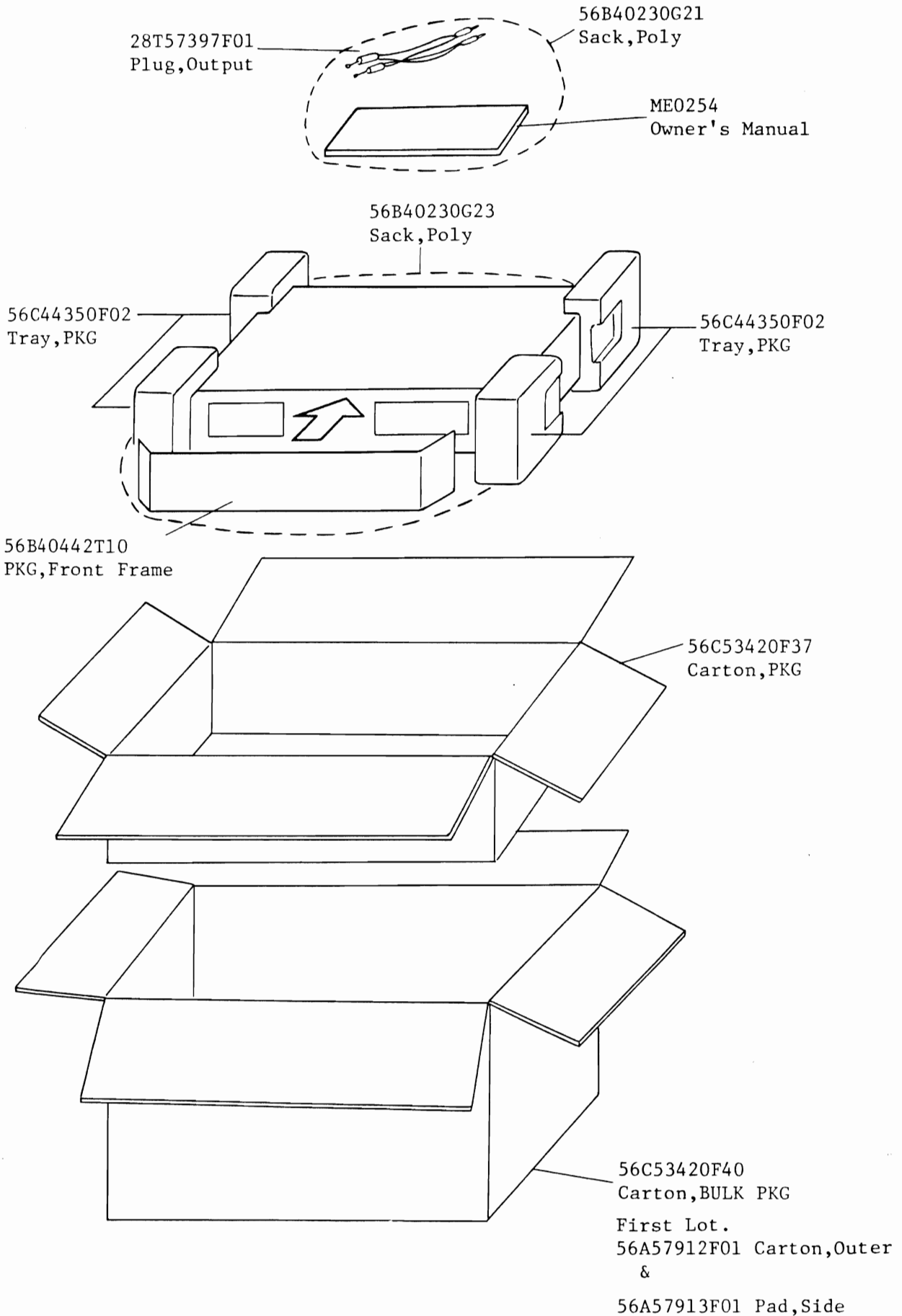

Master PCB Parts List

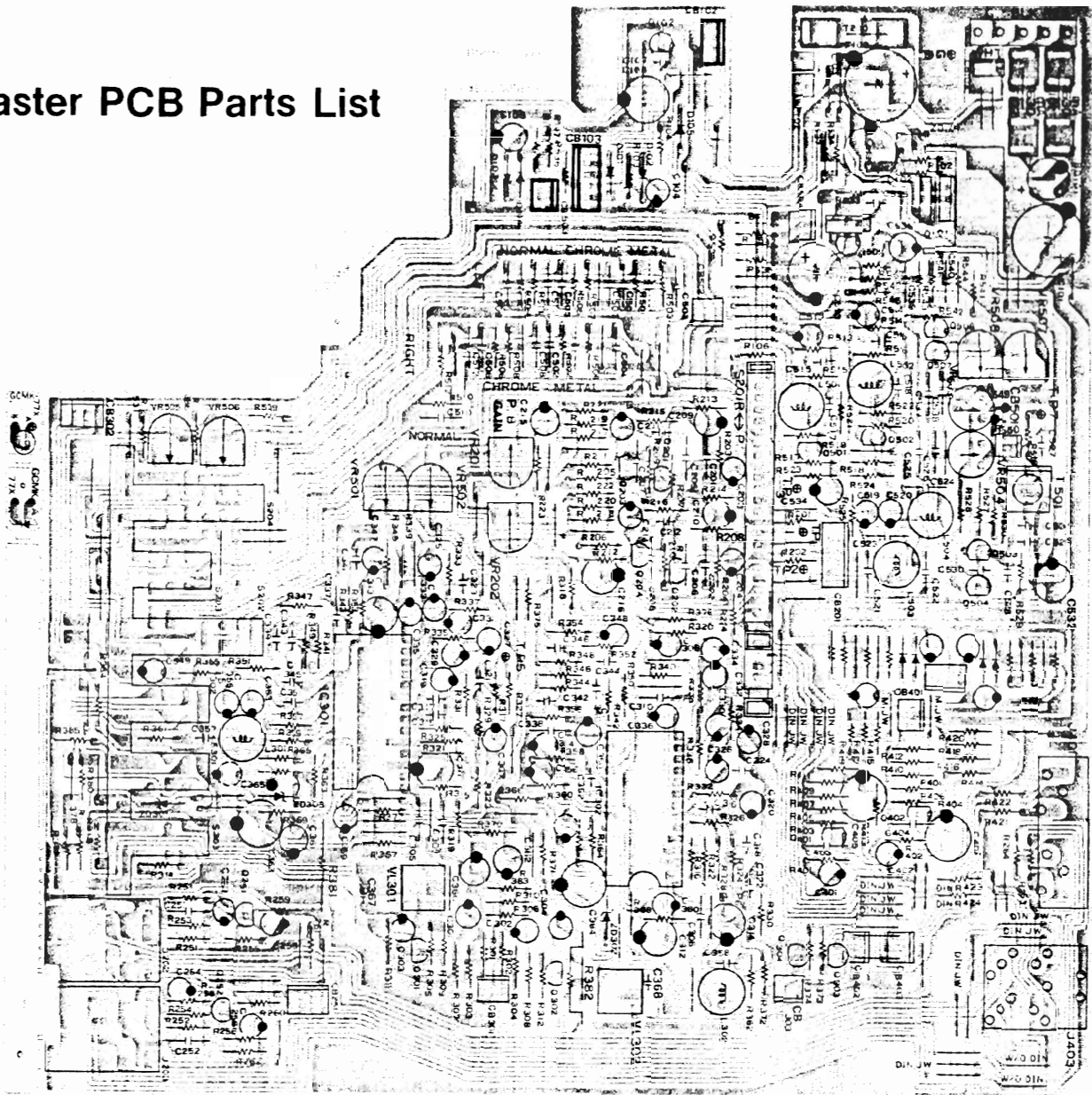

Symbol No.	Stock No.	Description
(Jack & Terminal)		
J202	09T55174F07	Jack, Mic Metal-6.5
J203	09T55174F07	Jack, Mic Metal-6.5
J401	09T57396F01	Plate, Phone 4P Jal
(Holder, Fuse SK, SG, AK)		
F101-103	09T45548F01	Holder, Fuse
(Fuse SK, SG, AK)		
F101	65T42077U14	Semko, 630mA
F102	65T42077U14	Semko, 630mA
F103	65T42077U09	Semko
(Resistor, Variable)		
VR201, 202	18T52946F15	22K (PB Level)
VR501, 502	18T52946F15	22K (Rec Level)
VR503, 504	18B44064J07	100K-1/2W (Bias)
VR505	18T52946F07	1K (Bias)
VR506	18T52946F05	470 (Bias)
(Switch)		
S201	40T56829F02	R/P Slide CL107K
S202-204		
S301-303	40T57675F01	Push, SUL
(Coil, Inductor)		
L301, 302	24T47741F01	36mH
L501, 502	24S41449F01	6800mH Radial
L503, 504	24T44499F01	27mH
(Trans, OSC)		
T501	25T56830F01	Trans, OSC

Symbol No.	Stock No.	Description
(Transistor)		
Q101	48T42620F02	2SD880Y
Q102	48T40081T03	2SA733 (P)
Q201, 202	48S40246G01	2SC732BL
Q203, 204	48S40246G01	2SC732BL
Q251, 252	48S40246G01	2SC732BL
Q301, 302	48S40246G01	2SC732BL
Q303, 304	48T51878F01	2SC2878A.A
Q401, 402	48S40832F04	2SC1318NC-S
Q501, 502	48S40246G01	2SC732BL
Q503	48S40832F03	2SC1318NC-R
Q504	48S40832F03	2SC1318NC-R
Q505	48S40832F04	2SC1318NC-S
(Diode, Bridge)		
BD101	48T50629F01	WL-02
(Coil)		
VL301, 302	24T51803F01	4.7mH Trap
(IC)		
IC301, 302	51T52160F01	HA12038-01
(Diode)		
D101	48T51582F01	MA-150
D102	48T51582F01	MA-150
D103	48T51582F01	MA-150
D104	48T5186F01	GP100
D105	48T5186F01	GP100

Master PCB Parts List

Symbol No.	Stock No.	Description
(Diode,Zener)		
ZD101	48T52739F86	HZ20-2
ZD301	48T52740F08	HZ12C-2
ZD302	48T52740F08	HZ12C-2
ZD303	48T52739F38	HZ6B-2
(Capacitor)		
C101	23S41198U56	1000uF 35V E1
C102	23S41198U57	470uF 25V E1
C103	23S41198U71	2200uF 16V E1
C104	23S40657F17	10uF 25V E1
C105	23S40657F18	22uF 25V E1
C106	23S41198U42	220uF 25V E1
C201,202	08S44505P44	390pF Ce
C203,204	23T42478F09	4.7uF 25V LN E1
C205,206	08S44505P45	470pF Ce
C207,208	08S44505P37	100pF Ce
C209,210	23S40657F07	47uF 10V E1
C211,212	08S40656F08	0.0039uF My
C213,214	23S40657F17	10uF 25V E1
C215	23S40657F10	10uF 16V E1
C216	23S40657F21	100uF 25V E1
C251,252	08S44505P49	1000pF Ce
C253,254	23T42478F09	4.7uF 25V LN E1
C255,256	23S40657F17	10uF 25V E1
C301,302	23S40657F28	1uF 50V E1
C303,304	23S40657F17	10uF 25V E1
C305,306	08S44505P50	1200pF Ce
C307,308	23S40657F28	1uF 50V E1
C309,310	08S44505P41	220pF Ce
C311,312	23S40657F14	100uF 16V E1
C313,314	23S40657F08	100uF 10V E1
C315,316	08S40656F15	0.015uF My
C317,318	08S40656F13	0.01uF My
C319,320	23S40657F10	10uF 16V E1
C321,322	08S40656F15	0.015uF My
C323,324	08S40656F16	0.018uF My
C325,326	23S40657F16	4.7uF 25V E1
C327,328	23T42478F21	0.33uF 50V LN E1
C329,330	23T42478F21	0.33uF 50V LN E1
C331,332	23S40657F28	1uF 50V E1
C333,334	23S40657F28	1uF 50V E1
C335,336	23S40657F10	10uF 16V E1
C337,338	08S44505P27	39pF Ce
C339,340	08S40656F01	0.001uF My
C341,342	08S40656F10	0.0056uF My
C343,344	08S40656F07	0.0033uF My
C345,346	08S40656F08	0.0039uF My
C347,348	23S40657F10	10uF 16V E1
C349,350	23S40657F16	4.7uF 25V E1
C351,352	08S40656F24	0.082uF My
C353,354	23T42478F19	0.15uF 50V E1
C355,356	23S40657F27	0.47uF 50V E1
C357,358	08S40656F04	0.0018uF My
C359,360	23S40657F10	10uF 16V E1
C361,362	23S40657F11	22uF 16V E1
C363	23S41198U41	220uF 16V E1
C364	23S40657F52	220uF 16V E1
C365,366	23S40657F13	47uF 16V E1
C367,368	08T44481F05	0.00047uF Pp
C401,402	23S40657F28	1uF 50V E1
C403,404	08S44505P33	68pF 50V Ce
C405,406	23S41198U41	220uF 16V E1
C501,502	08S44505P52	1800pF Ce
C503,504	08S44505P56	3900pF Ce
C505,506	08S44505P45	470pF Ce
C507,508	08S44505P47	680pF Ce
C509,510	08S44505P45	470pF Ce
C511,512	08S44505P49	1000pF Ce
C513,514	23S40657F16	4.7uF 25V E1
C515,516	08S40656F24	0.082uF My
C517,518	08S40656F13	0.01uF My
C519,520	23S40657F16	4.7uF 25V E1
C521,522	08S44505P43	330pF Ce
C523,524	08S44505P35	82pF Ce
C525,526	08S44505P37	100pF Ce

Symbol No.	Stock No.	Description
C527	08T52448F19	0.0018uF Pp
C528	08S40656F13	0.01uF My
C529	08S40656F07	0.0033uF My
C530	08S40656F07	0.0033uF My
C531	08S40656F11	0.0068uF My
C532	23S40657F21	100uF 25V E1
C533	23S41198U64	1000uF 16V E1
C534	23S40657F20	47uF 25V E1
C535	08S40656F25	0.1uF My
(Resistor)		
R101	06S44593P73	2.2K 1/4W Rd
R102	06S44593P73	2.2K 1/4W Rd
R103	06S44593P95	18K 1/4W Rd
R104	06S44593P77	3.3K 1/4W Rd
R105	06S44593P99	27K 1/4W Rd
R106	06S44593P37	68 1/4W Rd
R107	06S44593P93	15K 1/4W Rd
R201,202	06S44593P41	100 1/4W Rd
R203,204	06S44594P22	220K 1/4W Rd
R205,206	06S40106T14	100K 1/4W Rd
R207,208	06S44593P45	150 1/4W Rd
R209,210	06S40106T24	270K 1/4W Rd
R211,212	06S44593P97	22K 1/4W Rd
R213,214	06S44593P65	1K 1/4W Rd
R215,216	06S44593P38	1M 1/4W Rd
R217,218	06S44593P92	13K 1/4W Rd
R219,220	06S44593P95	18K 1/4W Rd
R221,222	06S44593P73	2.2K 1/4W Rd
R223	06S44593P97	22K 1/4W Rd
R224	06S44593P57	470 1/4W Rd
R251,252	06S44593P57	470 1/4W Rd
R253,254	06S44593P89	10K 1/4W Rd
R255,256	06S40106T30	470K 1/4W Rd
R257,258	06S40106T38	1M 1/4W Rd
R259,260	06S44593P89	10K 1/4W Rd
R261,262	06S44594P14	100K 1/4W Rd
R263,264	06S44593P91	12K 1/4W Rd
R301,302	06S44593P41	100 1/4W Rd
R303,304	06S44593P89	10K 1/4W Rd
R305,306	06S44594P24	270K 1/4W Rd
R307,308	06S44594P06	47K 1/4W Rd
R309,310	06S44593P74	2.4K 1/4W Rd
R311,312	06S44593P71	1.8K 1/4W Rd
R315,316	06S44593P83	5.6K 1/4W Rd
R317,318	06S44593P41	100 1/4W Rd
R319,320	06S44593P89	10K 1/4W Rd
R321,322	06S44594P08	56K 1/4W Rd
R323,324	06S44593P93	15K 1/4W Rd
R325,326	06S44593P82	5.1K 1/4W Rd
R327,328	06S44593P47	180 1/4W Rd
R329,330	06S44593P41	100 1/4W Rd
R331,332	06S44594P06	47K 1/4W Rd
R333,334	06S44593P84	6.2K 1/4W Rd
R335,336	06S44594P12	82K 1/4W Rd
R337,338	06S44594P38	1M 1/4W Rd
R339,340	06S44593P82	5.1K 1/4W Rd
R341,342	06S44593P81	4.7K 1/4W Rd
R343,344	06S44593P89	10K 1/4W Rd
R345,346	06S44594P10	68K 1/4W Rd
R347,348	06S44593P87	8.2K 1/4W Rd
R349,350	06S44593P50	240 1/4W Rd
R351,352	06S44593P49	220 1/4W Rd
R353,354	06S44594P08	56K 1/4W Rd
R355,356	06S44593P84	6.2K 1/4W Rd
R357,358	06S44594P12	82K 1/4W Rd
R359,360	06S44593P77	3.3K 1/4W Rd
R361,362	06S44593P65	1K 1/4W Rd
R363,364	06S44593P87	8.2K 1/4W Rd
R365,366	06S44593P87	8.2K 1/4W Rd
R367,368	06S44593P82	5.1K 1/4W Rd
R369,370	06S44594P02	33K 1/4W Rd
R371,372	06S44593P65	1K 1/4W Rd
R373,374	06S44593P75	2.7K 1/4W Rd
R375	06S44593P81	4.7K 1/4W Rd

Master Board PCB Parts List

Symbol No.	Stock No.	Description
R376	30A44183F06	Jumper Wire
R377	06S44593P83	5.6K 1/4W Rd
R378	06S44594P06	47K 1/4W Rd
R379	06S44593P83	5.6K 1/4W Rd
R380	06S44593P81	4.7K 1/4W Rd
R381,382	06T55179F47	180 2W Rf
R383	06S44593P57	470 1/4W Rd
R401,402	06S44593P41	100 1/4W Rd
R403,404	06S44594P12	82K 1/4W Rd
R405,406	06S44593P68	1.3K 1/4W Rd
R407,408	06S44593P68	1.3K 1/4W Rd
R409,410	06S44593P68	1.3K 1/4W Rd
R411,412	06S44593P68	1.3K 1/4W Rd
R413,414	06S44593P73	2.2K 1/4W Rd
R415,416	06S44593P40	91 1/4W Rd
R417,418	06S44593P40	91 1/4W Rd
R419,420	06S44593P40	91 1/4W Rd
R421,422	06S44593P65	1K 1/4W Rd
R501,502	06S44593P98	24K 1/4W Rd
R503,504	06S44593P93	15K 1/4W Rd
R505,506	06S44594P04	39K 1/4W Rd
R507,508	06S44594P16	120K 1/4W Rd

Symbol No.	Stock No.	Description
R509,510	06S44594P07	51K 1/4W Rd
R511,512	06S44594P04	39K 1/4W Rd
R513,514	06S44593P99	27K 1/4W Rd
R515,516	06S44594P14	100K 1/4W Rd
R517,518	06S40106T40	1.2M 1/4W Rd
R519,520	06S44593P72	2K 1/4W Rd
R521,522	06S44593P41	100 1/4W Rd
R523,524	06S44593P97	22K 1/4W Rd
R525	06S44593P57	470 1/4W Rd
R526	06S44593P01	2.2 1/4W Rd
R527,528	06D40801G11	6.8 1/2W Rd
R529,530	06S44594P02	33K 1/4W Rd
R531	06S44593P93	15K 1/4W Rd
R532	06S44593P58	510 1/4W Rd
R533	06S44593P58	510 1/4W Rd
R534	06S44593P63	820 1/4W Rd
R536	06S44593P65	1K 1/4W Rd
R538	06S44593P83	5.6K 1/4W Rd
R539	06S44593P37	68 1/4W Rd
R549	06S41801P48	22K 1/4W Rd
R550	06S41801P48	22K 1/4W Rd

FL Meter PCB Parts List

Symbol No.	Stock No.	Description
(FL Meter)		
E851	65T52950F01	FIP 12DW7YS
(Variable Resistor)		
VR801a,b	18T52946F17	47K
(IC)		
IC801a,b	51T42626F01	HA12019
(Transistor)		
Q801a,b	48S43525F05	2SC1815Y,GR
(Diode)		
D801a,b	48T43982F01	0A95 Ge.
(Capacitor)		
C801	23S40657F21	100uF 25V E1
C802a,b	23S40657F10	10uF 16V E1
C803a,b	23S40657F17	10uF 25V E1
C804a,b	23S40657F17	10uF 25V E1
C805a,b	23T42478F21	0.33uF 50V LN E1
C806	23S40657F21	100uF 25V E1
(Resistor)		
R801	06S44593P41	100 1/4W Rd
R802a,b	06S44593P89	10K 1/4W Rd
R803a,b	06S44594P29	430K 1/4W Rd
R804a,b	06S44593P71	1.8K 1/4W Rd
R805a,b	06S44594P18	150K 1/4W Rd
R806a,b	06S44594P50	3.3M 1/4W Rd
R807a,b	06S44593P85	6.8K 1/4W Rd
R808	06S44593P43	120 1/4W Rd
R809	06S44593P43	120 1/4W Rd
R810	06S44593P43	120 1/4W Rd
R811	06S44593P43	120 1/4W Rd
R812	06S44593P43	120 1/4W Rd
R813	06S44593P43	120 1/4W Rd

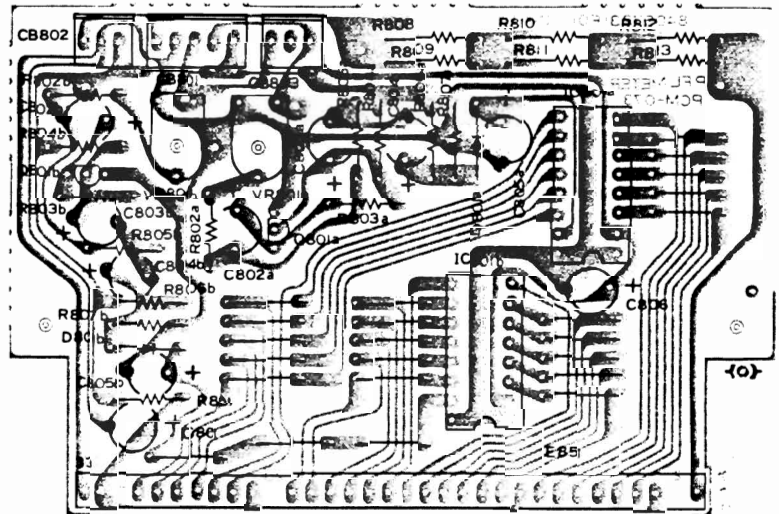

Rec LED PCB Parts List

Symbol No.	Stock No.	Description
(LED)		
	48T57622F01	SLF 106D

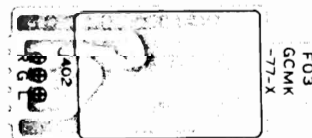

Head Phone PCB Parts List

Symbol No.	Stock No.	Description
(Jack, Mic)		
	09T55174F12	Metal-6.5

IC Handling Guide

HA12019.(IC801a,b Stock No. 51T42626F01)
Fluorescent Tube Driver for Bar Graph Display

(HA12019.Block Diagram)

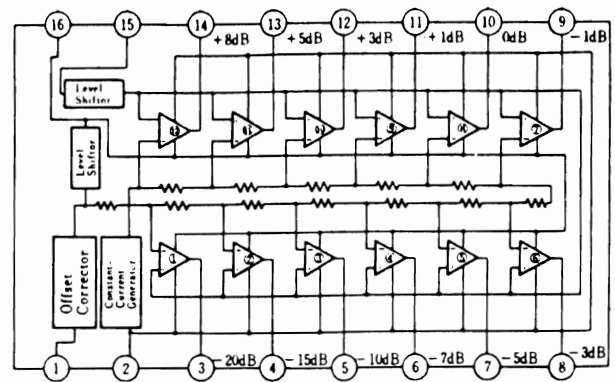

HA12038.(IC301,302 Stock No. 51T52160F01)
Dolby-Band-C Type Noise Reduction System

(HA12038 Block Diagram)

(Top View)

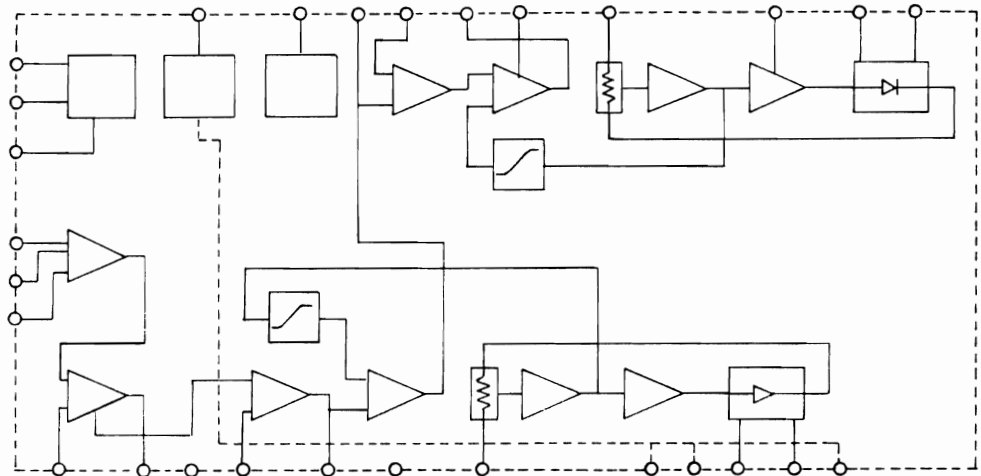

Destinations' Parts List

Symbol No.	Description	POWER SOURCE				
		SK 220V	SK 240V	EK 220V	UP 120V	AK 220V
		Europe	England & Australia	Europe & Other Areas	U.S.A. & Canada	Europe
52	Trans,Power	25T57308F01	25T57166F01	25T57166F01	25T56955F01	25T57166F01
24	SW,Power	40T45561F02	40T45561F02	40T45561F02	40T47454F01	40T45561F02
62	AC Cord	28T50179F03	30T43811F01	28T50179F03	28T40916U01	28T50179F03
61	Stopper,Cord	43B41625J02	07A40070U01	43B41625J02	43B41625J01	43B41625J02
59	Cover,Rear	15C50166F17	15C50166F18	15C50166F17	15C50166F16	15C50166F17
73	SW,Selector	Non Use	40T40705T04	40T40705T04	Non Use	40T40705T04
F101-103	Holder,Fuse	09T45548F01	09T45548F01	Non Use	Non Use	09T45548F01
F101-102	Fuse(Secondary)	65T42077U14	65T42077U14	Non Use	Non Use	65T42077U14
F103	Fuse(Secondary)	65T42077U09	65T42077U09	Non Use	Non Use	65T42077U09

LUX K-210 SCHEMATIC DIAGRAM

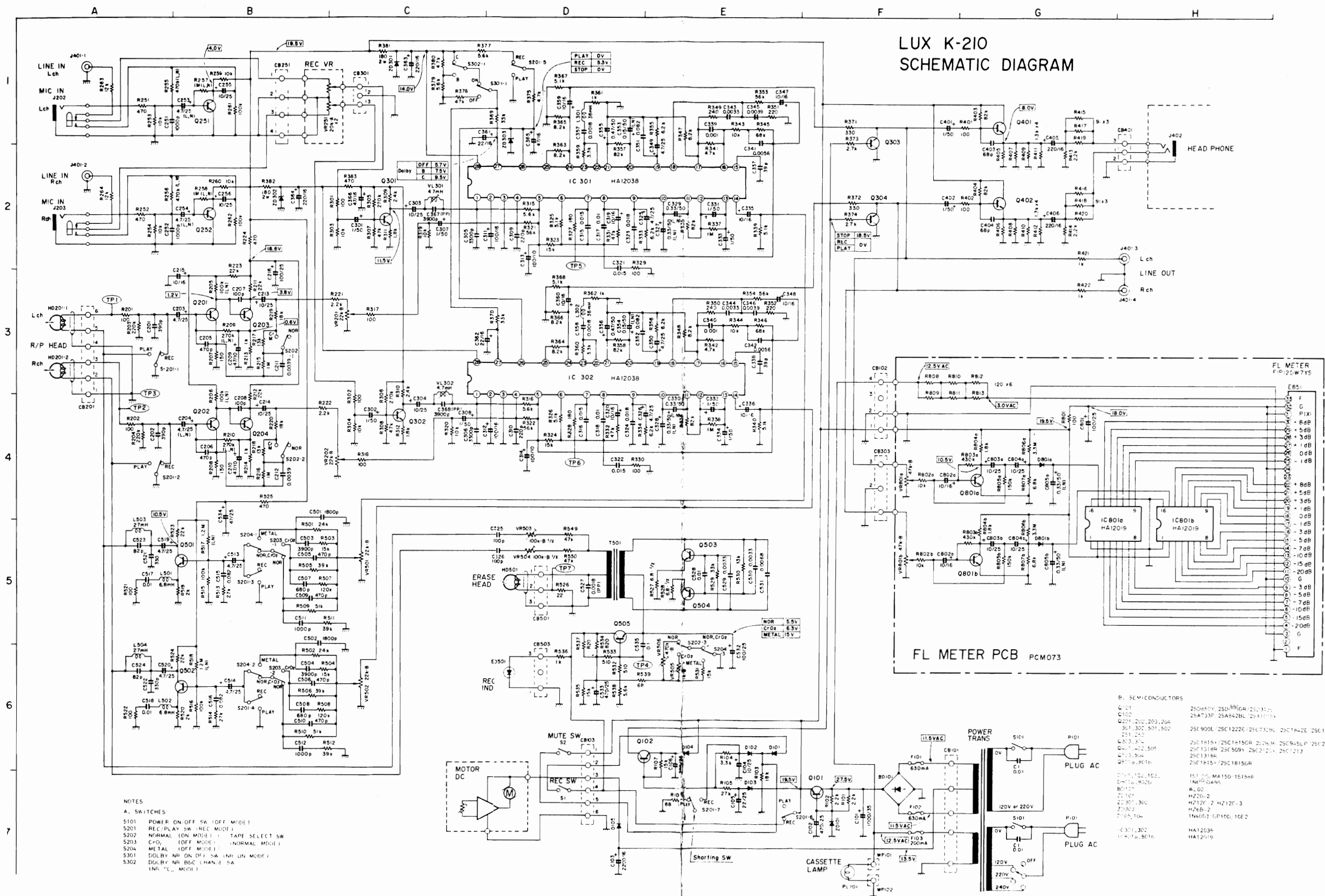

- NOTES**
- A. SWITCHES**
- S101 POWER ON/OFF SW. (OFF MODE)
 - S201 REC/PLAY SW. (REC MODE)
 - S202 NORMAL (ON MODE) / TAPE SELECT SW
 - S203 C-0 (OFF MODE) / (NORMAL MODE)
 - S204 METAL (OFF MODE)
 - S301 DOLBY NR ON/OFF SW. (NR ON MODE)
 - S302 DOLBY NR B/C (HANCE SW. (NR OFF MODE))

B. SEMICONDUCTORS

C101	2506BY, 2506BYGR/250310
C102	25A733P, 25A842BL/25A1015
C201, 202, 203, 204	251, 252
C301, 302, 301, 302, 301, 302	25C1900L, 25C1222E/25C0731H, 25C1442E, 25C1643E
C303, 304	25C1815X/25C1815GR, 25C06M, 25C0945LP, 25C2676
C401, 402, 505	25F1318H, 25C5099, 25C0225, 25C1213
C403, 504	25C1318H
C404, 601	25C1815X/25C1815GR
C501, 102, 103	151100, MA150, 151558
D101, 102, 103	1N4148, 1N4150
B101	W.62
Z1, 101	H220-2
Z2, 301, 302	H212C, 2, 4Z12C-3
Z3, 102	H26B-2
Z102, 104	1N4003, GP100, 10E2
IC301, 302	HA12038
IC801a, 801b	HA12019

Specifications

Heads:	Record/Playback head (Hexalam), Erase head (Double Gap Ferrite)
Wow & Flutter:	no more than 0.06 (W.R.M.S.)
Signal-to-Noise Ratio: (CCIR) weighted	Metal-Tape: Better than 57dB without NR Better than 52dB with Dolby-B-NR on Better than 69dB with Dolby-C-NR on CrO2-Tape: Better than 57dB without NR Better than 62dB with Dolby-B-NR on Better than 69dB with Dolby-C-NR on Nor.-Tape: Better than 55dB without NR Better than 60dB with Dolby-B-NR on Better than 67dB with Dolby-C-NR on
Frequency Response:	20Hz--19,000Hz (Metal Tape) (20Hz--17,000Hz+3dB) 20Hz--18,000Hz (CrO2 Tape) (20Hz--16,000Hz+3dB) 20Hz--16,000Hz (Nor. Tape) (20Hz--15,000Hz+3dB)
The 3rd Harmonic Distortion:	no more than 0.7% (Normal tape, 1kHz, 0dB)
Input Sensitivity:	line in: 100mV microphone: 300uV
Output Level:	line out: 500mV headphone: 1mW (8 ohms load)
Power Consumption:	20W
Dimensions:	453(W) x 275(D) x 110(H) mm (17.8" x 10.8" x 4.3")
Weight:	Net: 4.7 kgs (10.3 lbs.) Gross: 5.5 kgs (12.1 lbs.)

Specifications and appearance design subject to change without notice.

* NOISE REDUCTION CIRCUIT MADE UNDER LICENCE FROM DOLBY LABORATORIES.

THE WORD "DOLBY" AND THE DOUBLE-D SYMBOL ARE THE TRADE MARKS OF
DOLBY LABORATORIES.

* dbx is the trade mark of dbx Incorporated.

K-210



LUX CORPORATION, JAPAN

1-1, 1-CHOME, SHINSENRI-NISHIMACHI, TOYONAKA-SHI, OSAKA 565
PHONE 06-834-0004 CABLE LUXMAN TOYONAKA TELEX 5287106 LUXELE J